



AMP-119KFM
Spark Diverter (for Mixer)

User Manual

AMPE Technology Co.,Ltd.

www.ampecn.com

P r e f a c e

Thanks for using AMPE's high-performances spark diverter AMP series. The AMP series is manufactured with high-quality components and materials and incorporates the latest microprocessor technology available. AMPE continuously practices the design and innovation of the product and provides excellent products with professional attitude. Furthermore, it responds to the customers with professional service and benefits each other with the customers.

The manual is to be used for the installing, parameter setting, troubleshooting and daily maintenance of spark diverter. In order to assure the proper installing and usage of the product, please read this manual in detail before installing. Please keep this user manual at hand and distribute to all users for reference.

Welcome to visit the website www.ampecn.com.



ATTENTION!

1. First please carry out the delivery inspection and check whether there is damage caused by transportation process.
2. After unpacking, please compare with the packing list and check the type, specification and components of the product. If it does not conform to your order documents or if you have any questions regarding the product, you can contact to the dealer or the service office of our company.
3. Jiangsu Ampeon provides services of the three guarantee period 18 months from the delivery date.
4. Troubles due to lightening strike, water invasion and obvious artificial miss or damage etc. are not in the range of repair guarantee.
5. Metal & spark diverter series products are important products of the fore-spinning procedure in cotton spinning mill. But the users in cotton spinning mill should also take integrated measures in fire protection equipments, selection of material, management regulations etc. to assure the safety production.



CAUTION !

1. The power supply must first be shut down before the electric wiring.
 2. Wiring, repairing & maintenance of the machine should be carried out by electric professionals.
 3. Do not carry out compression test toward the inner components because the semiconductor units are easy to be broken down by the high voltage and are easy to damage.
 4. The circuit board CMOS integrated circuit is apt to static electricity damage. So you should take the static electricity prevention measure before touching the circuit board with hand.
 5. As the machine is installed to the pipe in high place, installing personnel should take safety measures. Suspending or bracket should be solid to prevent the machine from dropping down.
 6. Select safety area to install the equipment, prevent the high temperature & direct shinning and avoid humidity and splashing of the water drops.
-

Contents

| | |
|---|-----------|
| I. GENERAL | 3 |
| 1. Purpose of the product | 3 |
| 2. Technical Parameter | 5 |
| II. DESCRIPTION AND INSTALLATION OF COMPONENTS | 5 |
| 1. Description of Components | 5 |
| 2. Electrical Wiring | 10 |
| 2.1 Electrical wiring description of main terminal | 10 |
| 2.2 Control Box Electrical Wiring | 12 |
| 3. Grounding and Safety | 12 |
| III. COMMISSIONING AND MAINTENANCE | 13 |
| 1. Operation Panel | 13 |
| 1.1 Description of LCD Details | 13 |
| 1.2 LCD Page Display in Case of Fire Alarm | 14 |
| 1.3 Description of Keys | 14 |
| 2. Main Menu Page | 14 |
| 2.1 "Time Setting" Menu | 15 |
| 2.2 "System Parameters" Menu | 15 |
| 2.3 "Function Parameters" Menu | 16 |
| 2.4 "History" Menu | 17 |
| 2.5 "Communication Settings" Menu | 17 |
| 2.6 "About" Menu | 18 |
| 3. Fire Alarm Simulation Test and Maintenance | 18 |
| IV. COMMUNICATION | 19 |
| 1. Communication Baud Rate and Address Setting | 19 |
| 2. Communication Protocol Parameters | 19 |
| V. TROUBLESHOOTING | 21 |

I. GENERAL

1. PURPOSE OF THE PRODUCT

A fire alarm made specifically for Mixer is called AMP-119KFM Spark Diverter (for Mixer). The pipeline that uses wind power to move materials has the detector installed right there. Sparks can be detected and stopped in the pipeline to keep them from reaching the mixer; To simultaneously monitor the sparks produced inside the mixer in real time, two detections can be extended and put on the top of the mixer. When it is detected that there are sparks and combustion debris mixed in the pipeline, it will immediately give an audible and visual alarm, automatically stop the relevant equipment, and start the fire discharge mechanism at the same time to guide the flame containing cotton flow into the fire extinguishing bag, eliminate the potential fire hazard in the bud, and play the role of "preventing the fire from burning".

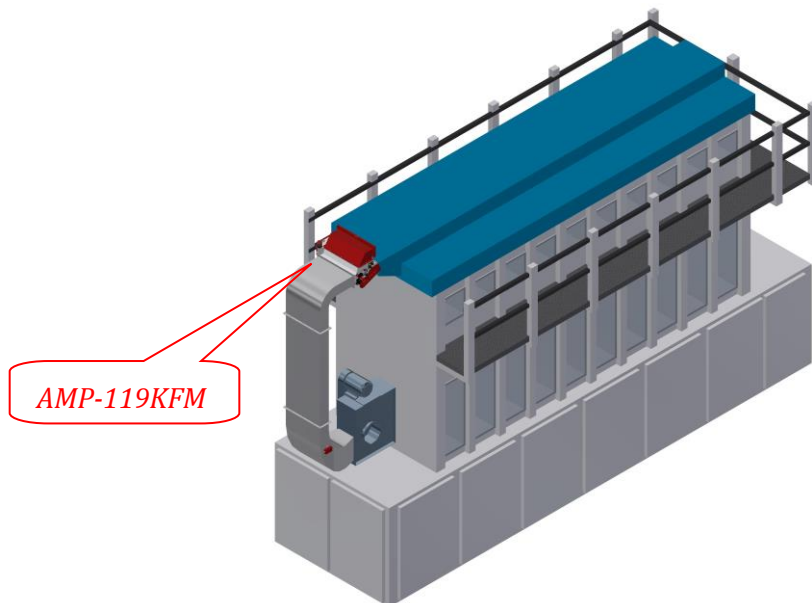

Figure 1: Installation of AMP-119KFM Spark Diverter on Trützschler Mixer

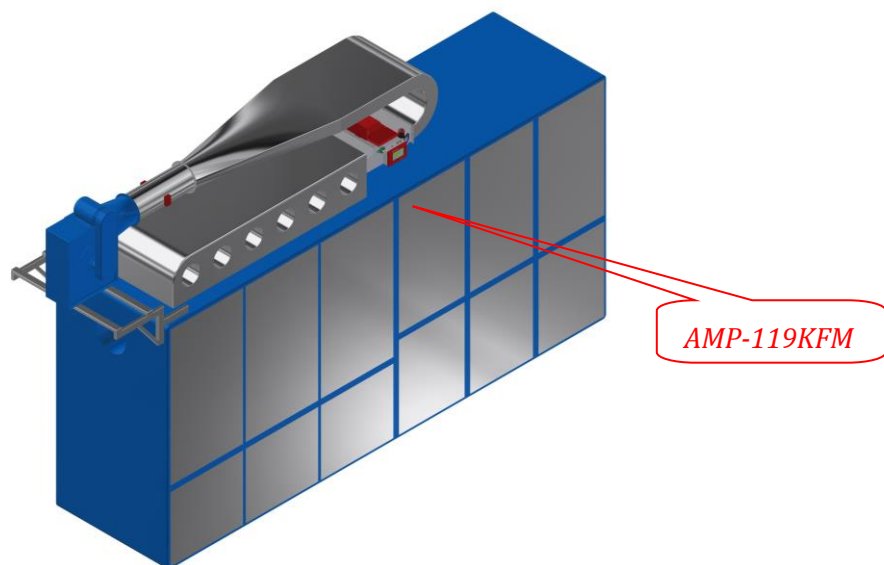

Figure 2: Installation of AMP-119KFM Spark Diverter on RIETER Mixer

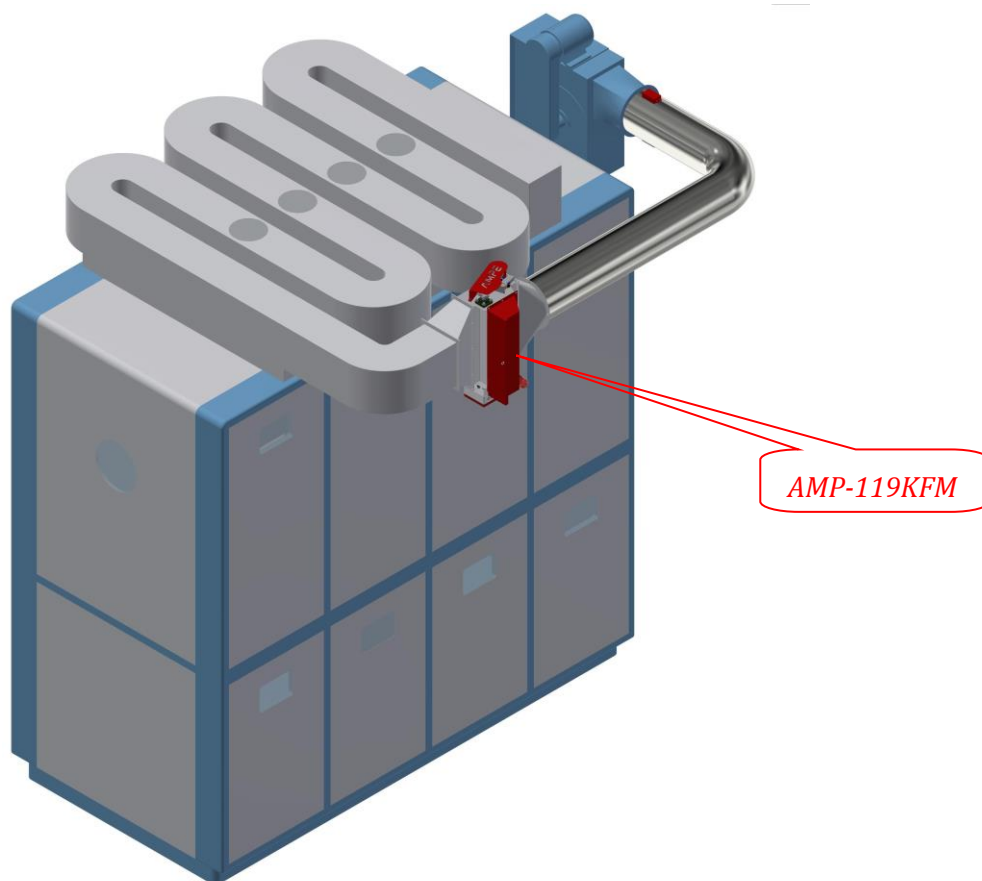

Figure 3: Installation of AMP-119KFM Spark Diverter on Qingdao Mixer

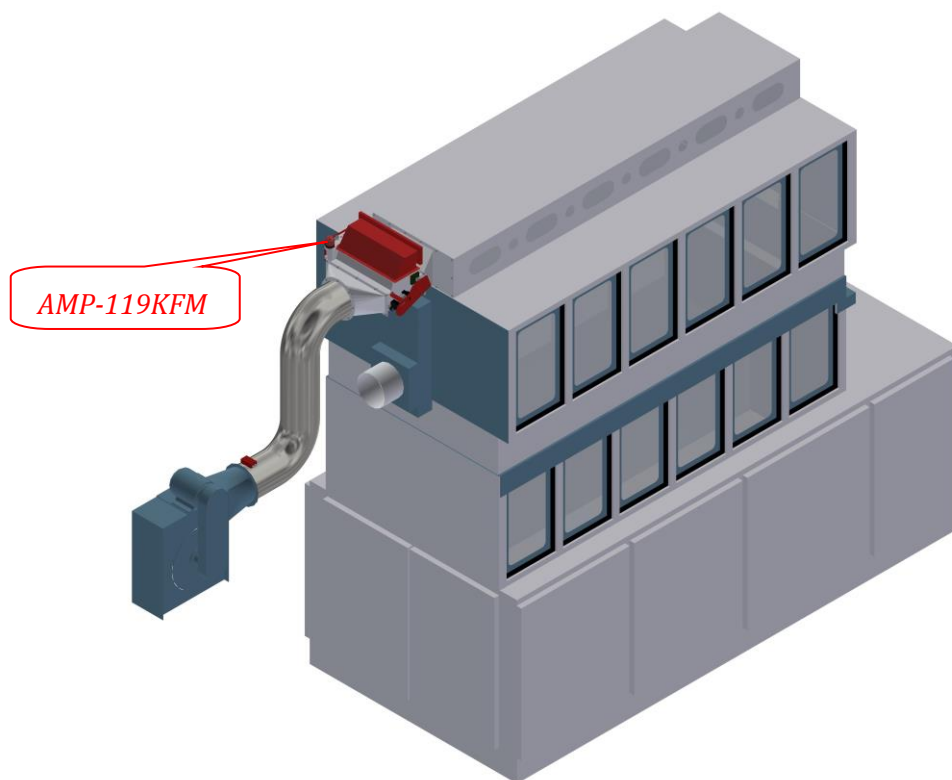

Figure 4: Installation of AMP-119KFM Spark Diverter on RIFA Mixer

2. TECHNICAL PARAMETER

- 1) Detection sensitivity: Φ 0.5mm spark, angle of view not less than 90°.
- 2) Response time: less than 100ms.
- 3) Working power supply: 100-240VAC.
- 4) Instrument power consumption: $< 45W$.
- 5) Pneumatic pressure range: 6~8 bar.
- 6) Contact load of output relay: AC220V/3A.
- 7) Alarm loudness: $> 100db$.
- 8) Environmental requirements: temperature - 10 °C~70 °C, relative humidity $\leq 65\%$.

II. DESCRIPTION AND INSTALLATION OF COMPONENTS

Correct electrical wiring and installation are the most crucial links in ensuring the best operation of the AMP-119KFMSpark Diverter. Please carefully read the following information before installation, and then accurately measure and assess the installation environment and conditions at the site.

1. DESCRIPTION OF COMPONENTS

1.1 Spark Detection

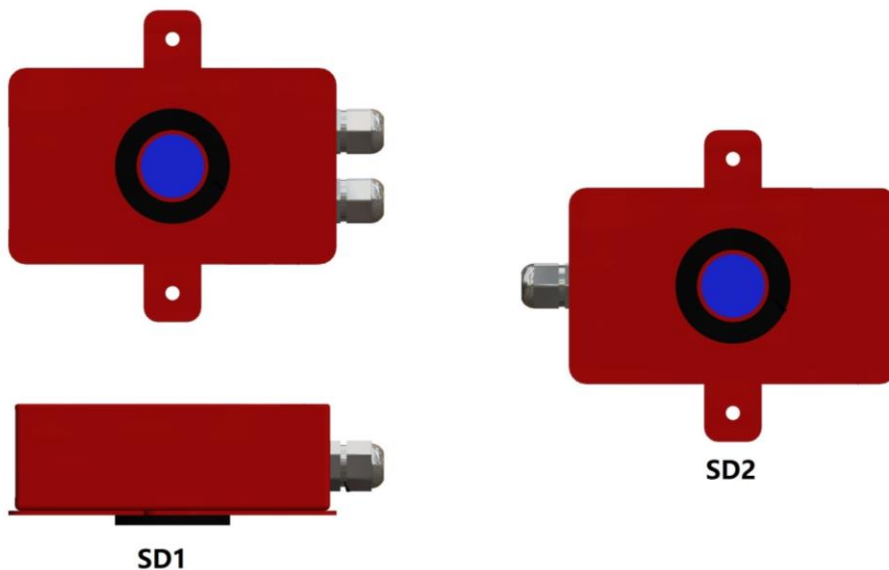

Figure 5: Component of AMP-119KFMSpark Detection

The installation bracket allows for direct installation of the spark detector on the pipeline and connection to the pipeline. The pipe's holes are opened by the 22mm hole opener, which also installs Spark Detector on both sides of the pipe.

A self-test bulb is included inside the SD1 detection. It is advised to pair SD1 and SD2 in order to activate the Spark Detection self-test feature.

1.2 Control Box

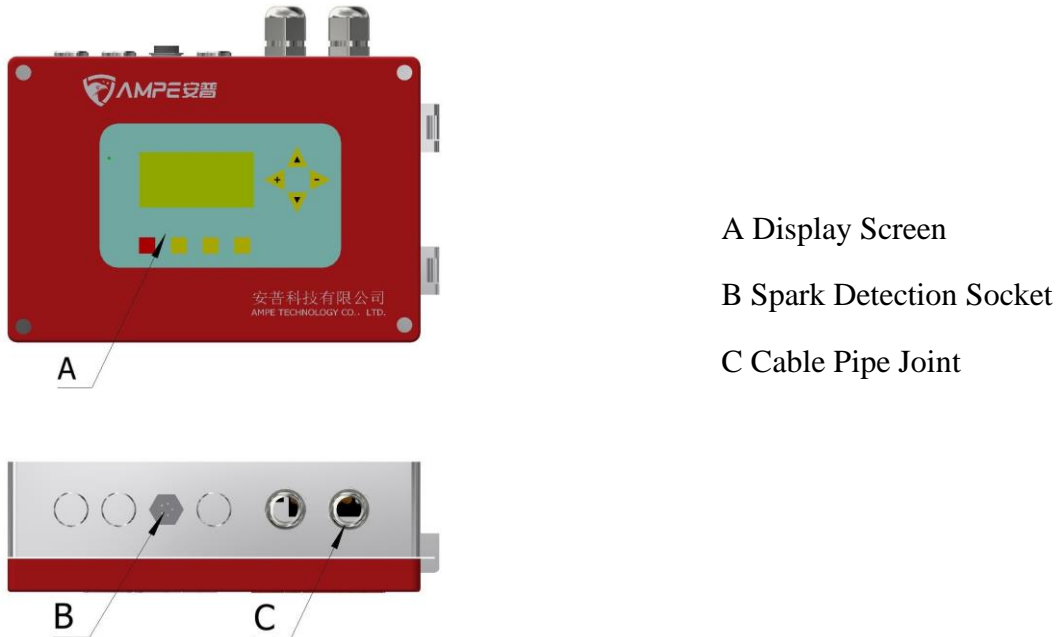

Figure 6a: Outline of AMP-119KFMSpark Diverter Control Box

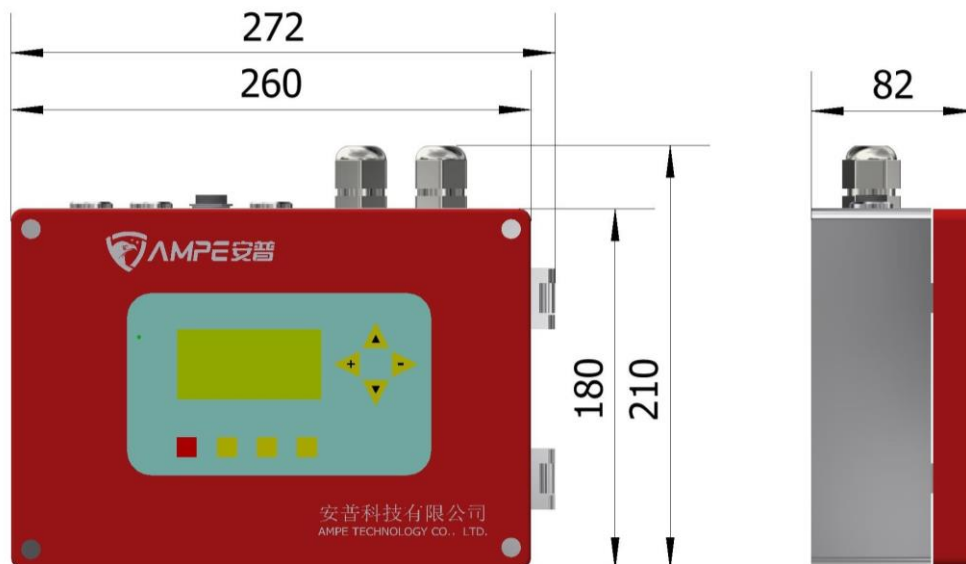
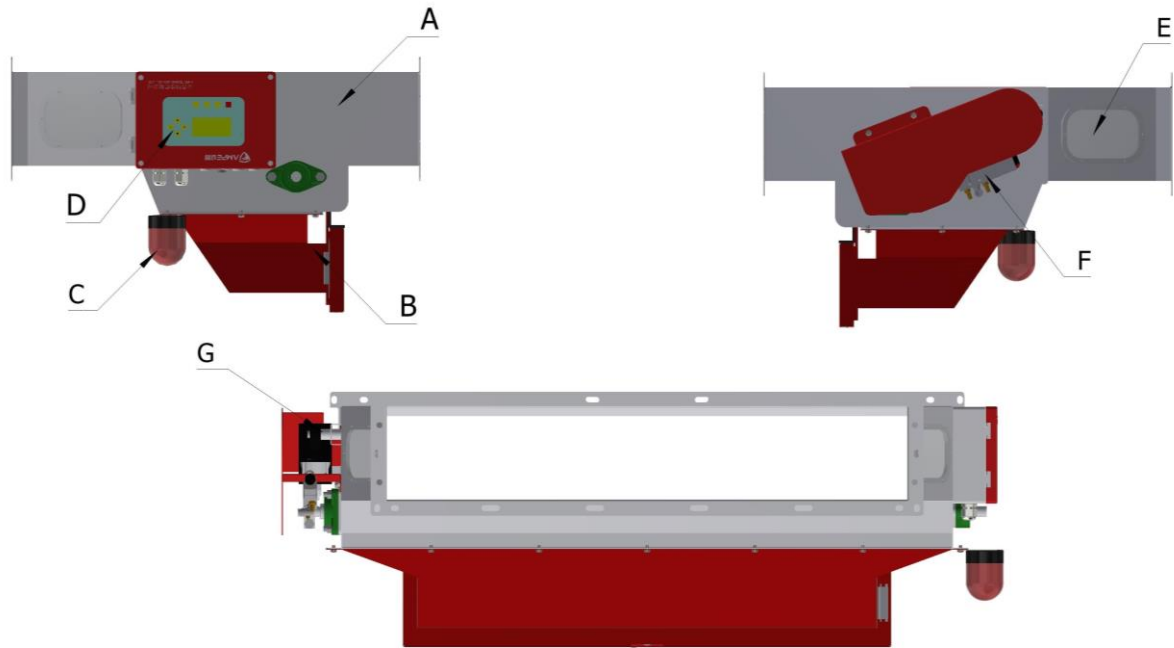

Figure 6b: Dimension of AMP-119KFMSpark Diverter Control Box

1.3 Automatic Fire Discharge Mechanism

A three-way fire discharge valve and an integrated fire discharge mechanism are part of the fire-fighting bag, which is comprised of fire-retardant materials. The cotton conveying pipeline is instantly shut off by the fire discharge valve after the fire alarm is activated, and at the same time, the moveable door of the cloth bag box is forced open. The fire extinguishing bag emerges from the box, and the fire cotton is immediately deposited inside.



A. Fire Discharge Mechanism B. Fire Extinguishing Bag C. Audible and Visual Alarm D. Control Box E. Observation Window F. Solenoid Valve G. Cylinder

Figure 7: Name of Components of Automatic Fire Discharge Mechanism

The cotton conveying pipeline is directly connected to the fire discharge mechanism, which is placed using metal hangers. It needs to be installed in the arrow's direction. The trash remover requires a reliable, clean air source of 6–8 bar because it uses a quick response pneumatic motor.

Notes

When the power is on, avoid touching and cleaning the flap location of the fire discharge mechanism to prevent risk from unexpected action!

1.4 Standard Installation

1.4.1 Installation Requirements

A false alarm could be caused by direct sunshine or reflections on the of detecting region. Spark Detection and the fire exhaust mechanism should be separated by a distance L of at least 1.5 meters.

1.4.2 Installation of Fire Exhaust Mechanism

The cotton conveying pipeline is directly connected to the automatic fire discharge mechanism. During installation, pay close attention to the cotton inlet and outlet directions.

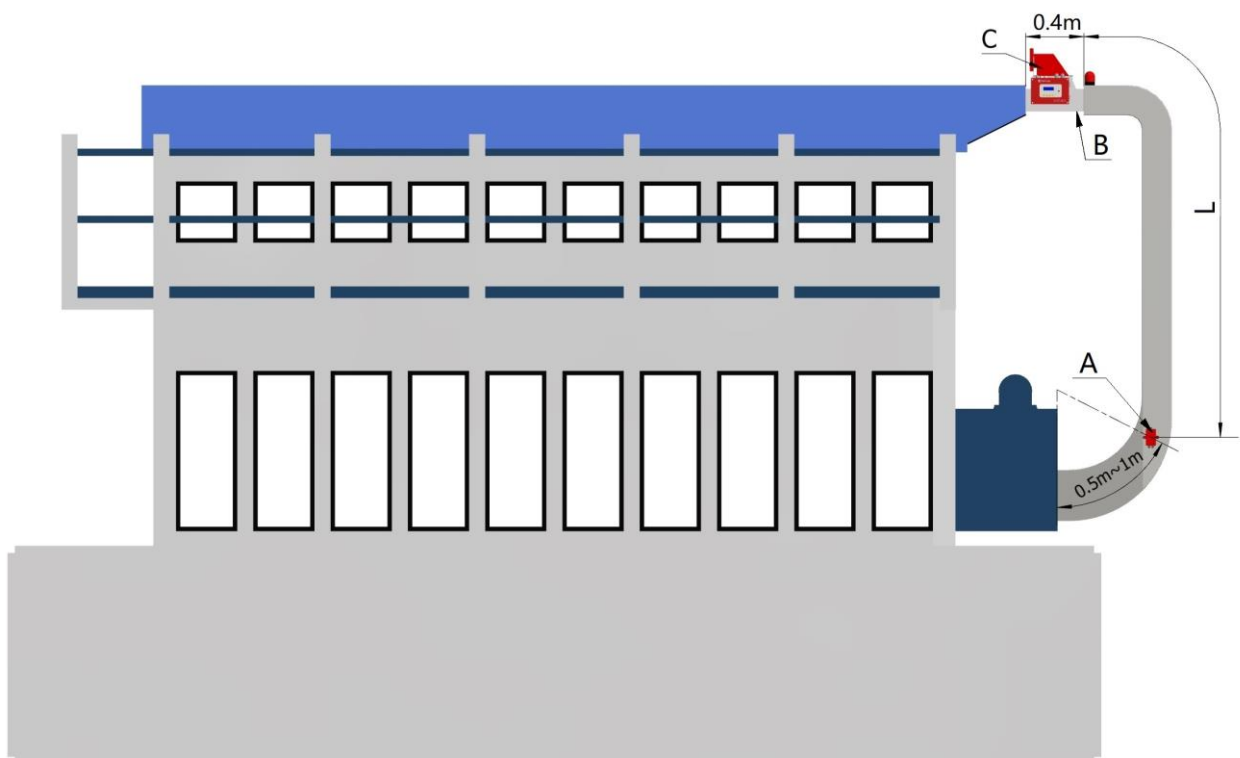

A. Spark Detection B. Fire Exhaust Mechanism C. Control Box

Figure 8: Installation of AMP-119KFM Spark Diverter Trützscher Mixer

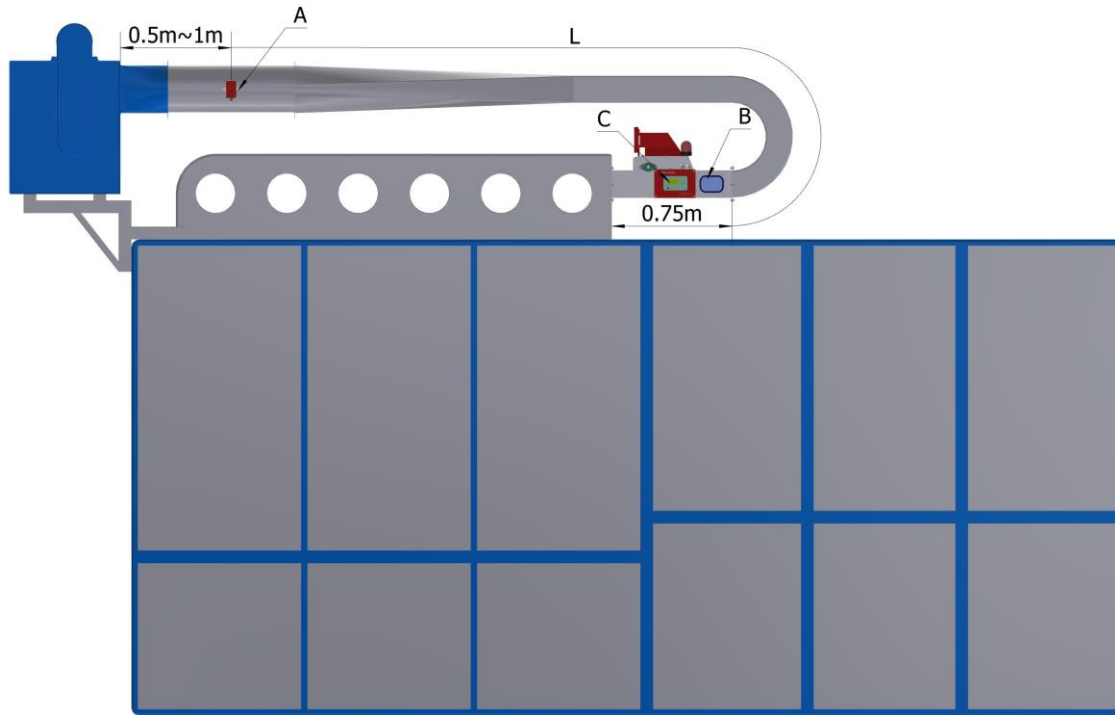

A. Spark Detection B. Fire Exhaust Mechanism C. Control Box

Figure 9: Installation of AMP-119KFM Spark Diverter RIETER Mixer

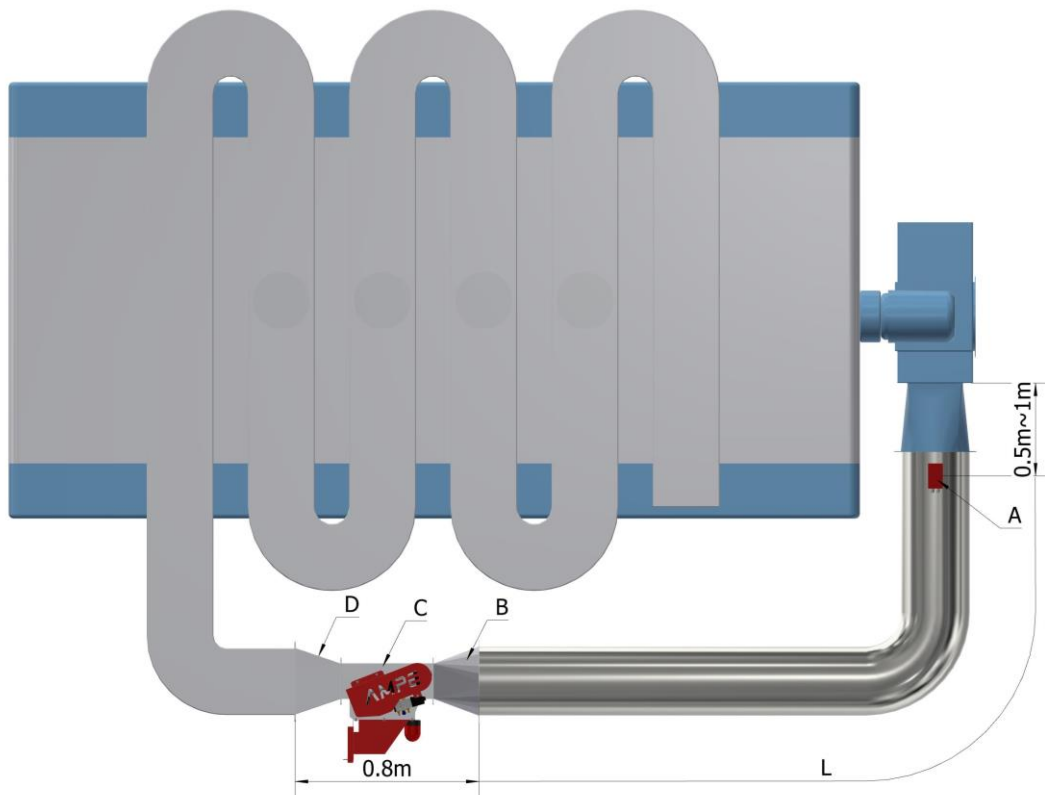

A. Spark Detection B. Square-to-Round C. Fire Exhaust Mechanism D. Square-to-Square

Figure 10: Installation of AMP-119KFM Spark Diverter Qingdao Mixer

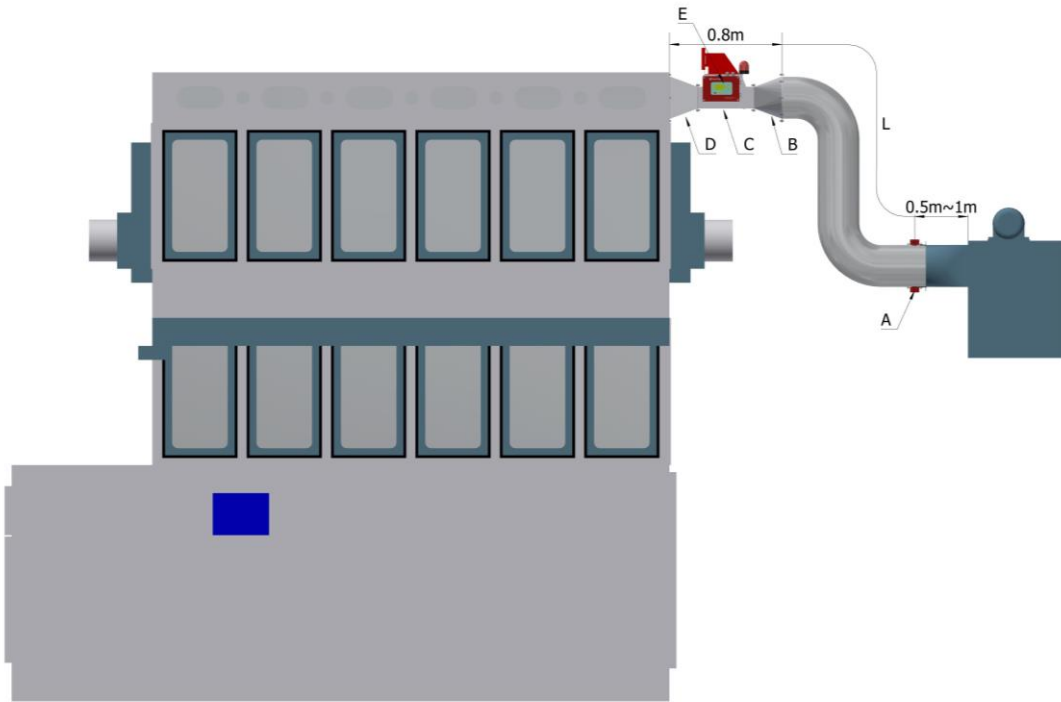

- A. Spark Detection B. Square-To-Round C. Fire Exhaust Mechanism D. Square-To-Square
E. Control Box

Figure 11: Installation of AMP-119KFM Spark Diverter RIFA Mixer

2. ELECTRICAL WIRING

2.1 ELECTRICAL WIRING DESCRIPTION OF MAIN TERMINAL

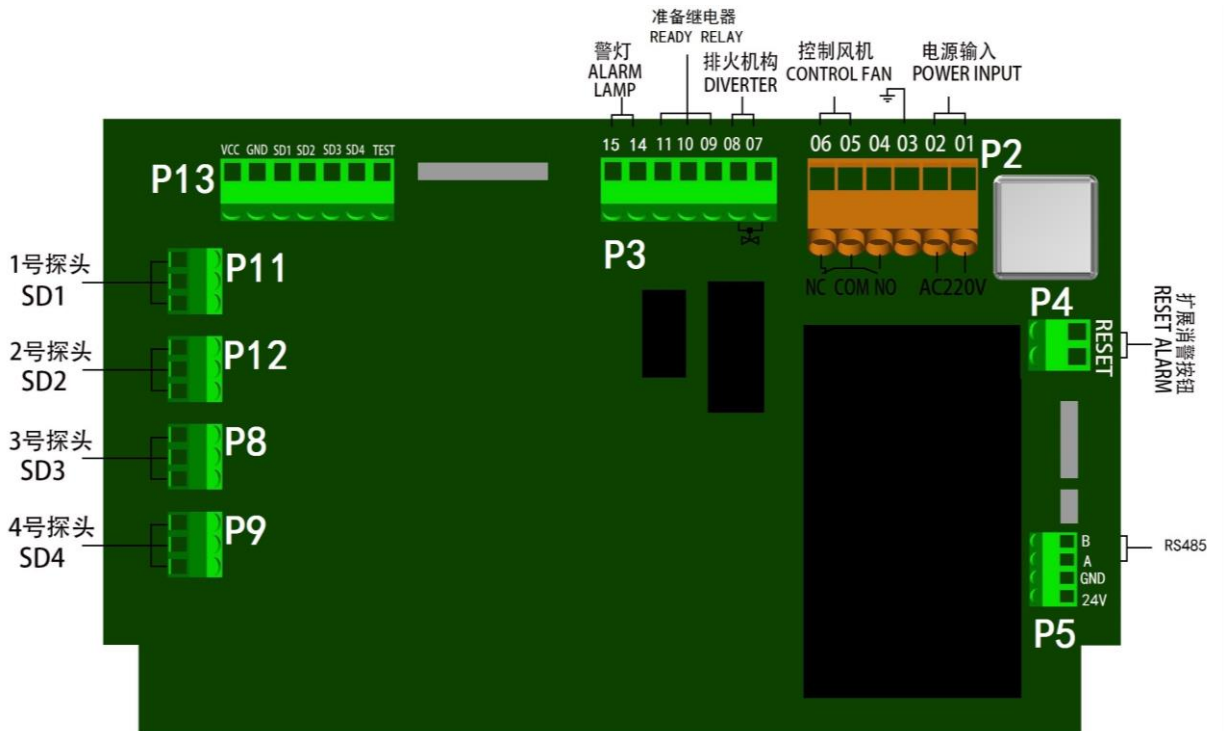

Figure 12: Schematic Diagram of Main Wiring Terminal

a. Incoming AC220V power lines are at terminals 1 and 2, while grounding wire is at terminal 3. Power sharing with other devices that could emit interference radiation must be avoided. Please provide power separately if at all possible. Take close attention to prevent alarms from shutting off its own power supply.

 **Notes**

Usual practice is to use the workshop distribution cabinet's one live line and zero line of the power supply incoming line. The AC380V/AC220V control transformer in the electrical control cabinet produces an AC220V power supply; do not use it.

b. In order to swiftly stop the fan or other connected machinery in the event of a fire, terminals 4 "NC," 5 "COM," and 6 "NO" are a series of passive relay contact outputs.

c. To operate the solenoid valve on the trash collection mechanism, terminals 7 and 8 are used (the working voltage of the solenoid valve is DC20V-24V). RVV1.0mm² insulated sheath wire is advised because the equipment is mounted on the pipeline.

d. Four-way Spark Detection can be connected using the SD1, SD2, SD3, and SD4 terminals; SD1 and SD2 are the original two Spark Detection, while SD3 and SD4 are extension terminals for external Spark Detection (user optional).

e. The outputs of another set of passive relay contacts are terminals 9, 10, and 11. Identify the machine's operational status and serve as the preparatory relay when the fault is confirmed.

f. Terminals 14 and 15 are externally connected with audible and visual alarm signals, 14 are positive and 15 are negative.

2.2 CONTROL BOX ELECTRICAL WIRING

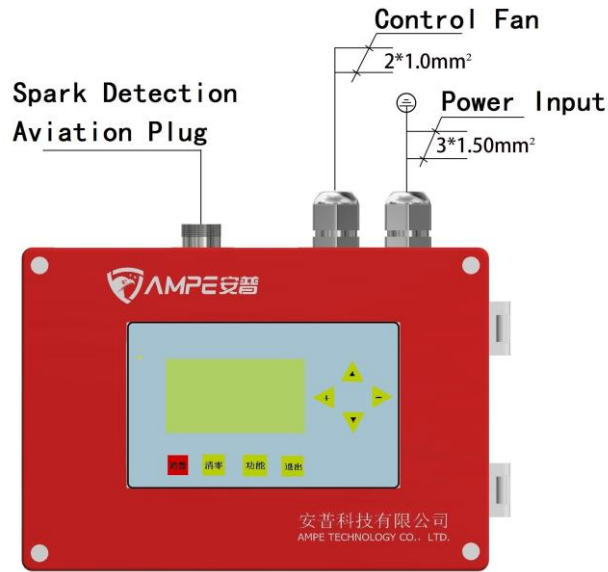

Figure 13: Electrical Connection of Control Box and Various Components

3. GROUNDING AND SAFETY

- 1) The equipment must be grounded individually and the grounding must be done in accordance with applicable safety regulations.
- 2) The grounding wiring ought to be as brief as feasible, according to the advice. It is prohibited to share the space with other pieces of machinery;
- 3) The machine, especially the actuator, should be switched down for repair;
- 4) After the spark alarm, promptly cut off the process's main power supply before putting out the fire;
- 5) To maintain safety, more than two individuals must perform any climbing maintenance or spark alarm testing;
- 6) During the action test of the actuator flap, personnel safety must be guaranteed.

III. COMMISSIONING AND MAINTENANCE

1. OPERATION PANEL



Figure 14: Operation Panel and Main Working State

1.1 DESCRIPTION OF LCD DETAILS

| No. | Display | Function or Meaning |
|-----|--------------------|--|
| 1 | 2022-01-23 | Date display: January 23, 2022 |
| 2 | 08:29 | Time display: 08:29 |
| 3 | 【SD】 ①② | In case of spark alarm, display the of number of alarm |
| 4 | ↔0 | There are 0 alarm records |
| 5 | Function → Menu | ① Press the "Function" key to enter the menu page. ② When the keyboard is locked, "Keyboard locked" is displayed. |

Notes

When working, these are the contents that are shown on the home page. The LED flashes to signal that there is a new alarm message while the LED is always on to show that the control system board has been powered on to the usual operational state. To get things back to as they were, press the "Cancel Alarm" key.

1.2 LCD PAGE DISPLAY IN CASE OF FIRE ALARM

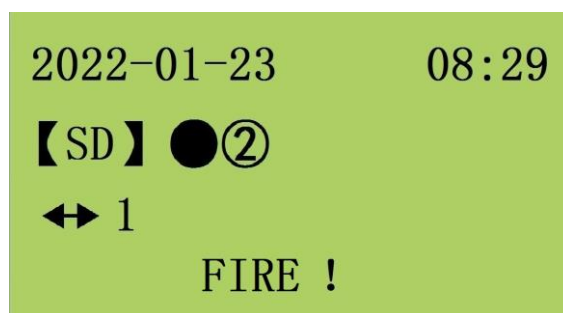

Figure 15: LCD Page Display in Case of Fire Alarm

When an alarm occurs, the LED indicator will flash, the instrument will send an audible and visual alarm signal and stop, "[SD] ● ②" means Spark DetectionSD1 alarm. In the alarm state, press the "Cancel Alarm" key to release the alarm state, and the instrument will return to its normal working state.

1.3 DESCRIPTION OF KEYS

Press the function key (press the "function+▲" key when the keyboard is locked) to enter the menu page.

- 1) "Alarm elimination" key, which eliminates the function of the alarm.
- 2) "Reset" key, press and hold this key to enter self-test.
- 3) "Function" key to switch menu pages. If the keyboard is locked, press the "Function" and "▲" keys at the same time to enter the parameter setting page.
- 4) "Exit" key, press this key to return to the main work page at the parameter setting page.
- 5) "▲" Up key, "▼" Down key, "◀" Left key, "▶" Right key, these four keys

It can switch parameter setting items and change the size of parameter values.

2. MAIN MENU PAGE

The main menu page includes six submenus: "1. Time Setting", "2. System Parameters", "3. Function Parameters", "4. History", "5. Communication Setting", and "6. About".

Click the "Exit" button to return to the main page.

Press the "Function" key on the main work page to enter the parameter setting menu page.

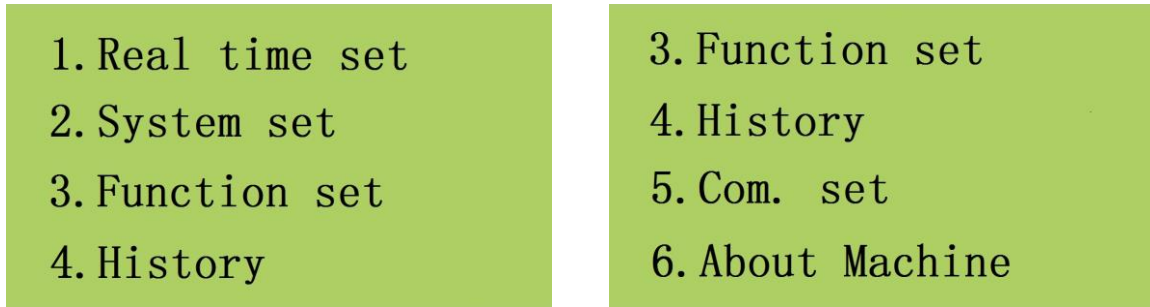

Figure 16: Parameter Setting Main Menu Page

Press the "Function" key to enter the time setting menu when the cursor flashes in the "1. Time setting" menu item, then press the "▲, ▼" keys to move the item where the cursor is located up and down on the screen. Finally, press the "Function" key to enter the parameter setting where the cursor is located or the item to be viewed.

2.1 "TIME SETTING" MENU

After entering the time setting menu, press "▲, ▼" to switch the required year/month/day, hour: minute" ◀, ▶" Key to change the size of the value, and press the "Exit" key to return to the main work page after setting.

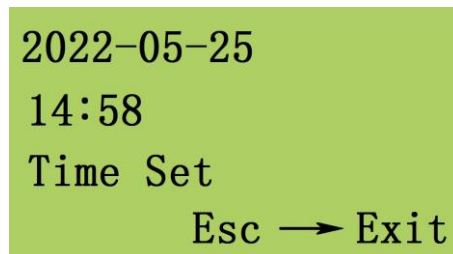

Figure 17: "Time Setting" Menu Page

2.2 "SYSTEM PARAMETERS" MENU

After entering the system parameter menu, press the "▲, ▼" key to switch the cursor up and down between the parameter setting items.

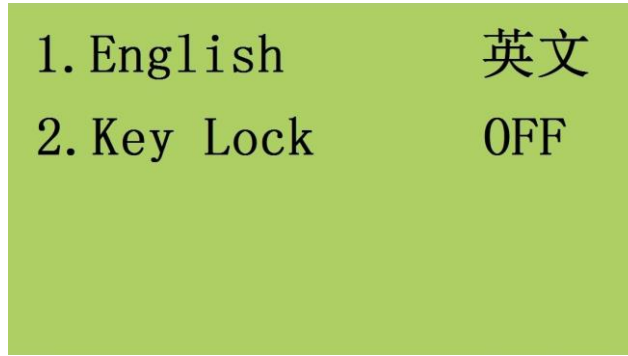

Figure 18: "System Parameters" Menu Page

1) The language selection button is visible since the pointer flashes in the "1. Chinese" line: To switch between "Chinese" and "English," use the "◀, ▶" Key on your keyboard.

2) The cursor flashes in the "2. Keyboard lock" line, indicating that the keyboard lock or unlock can be set: press“ ◀, ▶” Press the key to switch the keyboard lock on "ON" and off "OFF". OFF means the keyboard lock is closed. You can press the key after returning to the main page.

2.3 "FUNCTION PARAMETERS" MENU

After entering the function parameter menu, press "▲, ▼" to switch the cursor up and down between the two groups of function parameter setting items.

1) The "1. Detection mode" line's pointer flashes, suggesting that you can press the "◀, ▶" Key to change the Spark Detection's detection mode. Both twin probe and four probe detection modes are supported by this device. As required, users can include SD3 and SD4Spark Detection.

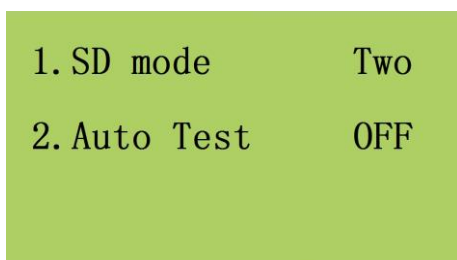

Figure 19a: Detection Mode Menu Page

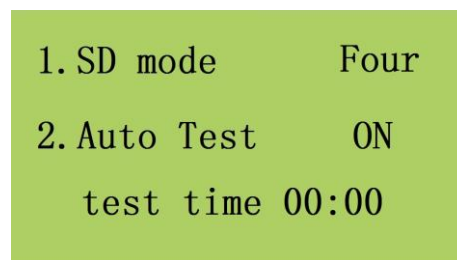

Figure 19b: Automatic Detection Menu Page

2) The cursor flashes in the "2. Automatic detection" line, indicating that you can press“ ◀, ▶” Key to turn on or off the spark function self-test function: when the "automatic detection" item displays "ON", the "detection time 00:00" will be displayed at the bottom of the page. You can press the "▲, ▼" key to switch the cursor to flash at the time position, and press“ ◀, ▶” Key to set the

time for automatic detection of spark function within 24 hours. If the automatic detection is ON, the spark function will be automatically detected at the set time every day.

2.4 "HISTORY" MENU

On the parameter setting menu page, when the cursor parameter setting "4. History" flashes, press the "Function" key to enter the history query page, press the "◀, ▶" Key to read the spark alarm record.

| Date | Time |
|--------------|-------|
| 22-04-09 | 15:14 |
| Count Alarm: | 05 |
| SD: 1 | → |

Figure 14: History Query Page

"Fire alarm record: 05" indicates the fifth alarm record of the equipment; "22-04-09 15:14": record the spark alarm time as 15:14 on April 9, 2022; "SD: 01" indicates that the Spark Detection number of the alarm is No. 1 Spark Detection; Press "▶" Key to view the previous fire alarm records; "Exit" key returns to the main work page.

2.5 "COMMUNICATION SETTINGS" MENU

The settings for the reserved RS485 communication interface (P5 terminal) on the control board are found in the "Communication Settings" menu.

When the parameter setting "5. Communication setting" flashes on the parameter setting menu screen, hit the "Function" key to access the communication setting page.

| | |
|-------------------|------|
| 1. Com. addss | 01 |
| 2. Baudrate | 9600 |
| 3. Modbus network | |
| (8, N, 2 RTU) | |

Figure 15: Communication Setting Page

1) Press“ ◀, ▶” The key can be used to set the communication address. The communication address value can be set between 1-32: if set to 1, the communication address of this machine is No. 1;

2) RS-485 uses the Modbus network communication protocol. The baud rate can be selected between 9600bit/s, 19200bit/s and 38400bit/s, and the factory setting is 9600bit/s. The format of communication data is "8, N, 2, RTU".

2.6 “ABOUT” MENU

On the parameter setting main menu page, when the cursor parameter setting "6. About" flashes, press the "Function" key to enter the about this machine page to obtain the equipment name, production date and version information.

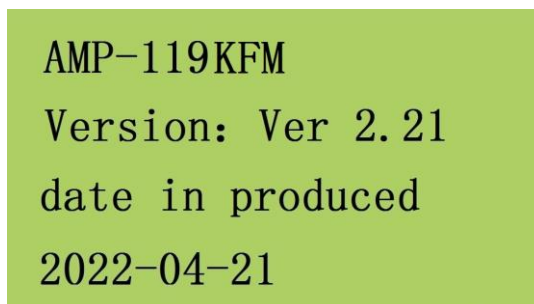

```
AMP-119KFM
Version: Ver 2.21
date in produced
2022-04-21
```

Figure 16: About

3. FIRE ALARM SIMULATION TEST AND MAINTENANCE

a. The fire alarm can only be activated during normal use after determining the cause. When a tiny spark sets off the fire alarm, it must also be turned off for more than 30 minutes and can only be restarted after making sure everyone is safe.

b. A simulated spark test device is included with the AMP-119KFM, version 21. If you press and hold the "reset" key for longer than three seconds while the system is in operation, the system will perform a spark self-test. You can enter the "automatic detection" under the "function parameters" page on the main page of the work (see Chapter 2.3 for details). When the spark detecting self-inspection is in a healthy state, the display is depicted in Figure 17a. The display is presented in Figure 17b if the spark detection is unsuccessful. To turn off the fault alarm, press the "alarm removal" button one again. Only SD1 and SD2 have the automated spark detection feature while the equipment is in the four-probe mode; SD3 and SD4 must be manually tested.

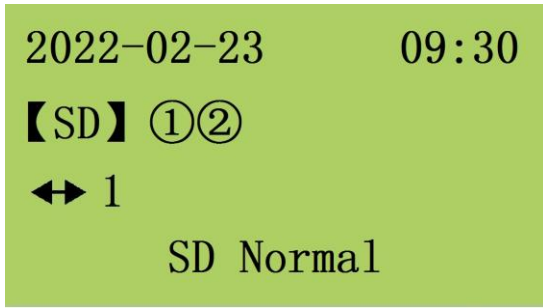

Figure 17a: Spark Detection Test Normal Page

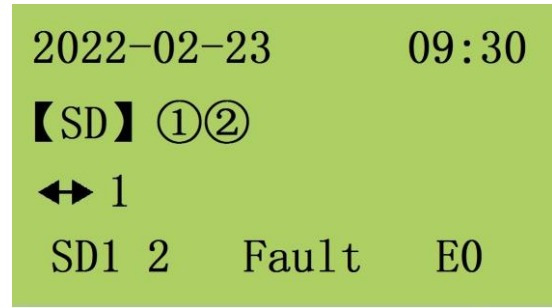

Figure 17b: Spark Detection Test Fault Page

c. At least once every two to three weeks, the fire alarm must be tested and examined to make sure it is in good working order.

d. Spark Detection lens surfaces need to be routinely examined and cleared of dust and dirt.

e. For the flap mechanism to stay in place and not become stuck or shift, the actuator needs to be periodically inspected and serviced.

IV. COMMUNICATION

1. COMMUNICATION BAUD RATE AND ADDRESS SETTING

| Parameter | Setting Range | Factory Setting |
|----------------|--|-----------------|
| Baud Rate | b1 (9600bit/s) b2 (19200 bit/s) b3 (38400 bit/s) | b1, 9600 |
| Postal Address | d1 ~ d32 | d1 |

Table 2: Communication Parameter Setting Table

Note: The factory setting is baud rate 9600, and the communication address is 1;

2. COMMUNICATION PROTOCOL PARAMETERS

2.1 Communication Data Format

11-bit Character Box (8, N, 2 For RTU)

| | | | | | | | | | | |
|-----------|---|---|---|---|---|---|---|---|----------|----------|
| Start bit | 0 | 1 | 2 | 3 | 4 | 5 | 6 | 7 | Stop bit | Stop bit |
|-----------|---|---|---|---|---|---|---|---|----------|----------|

2.2 RTU MODE DATA STRUCTURE

| | |
|----------|--|
| START | Keep no input signal greater than or equal to 10ms |
| address | Postal Address |
| Function | Function Code: |

| | |
|-------------|---|
| DATA (n-1) | Data: n × 8-bit data N<=40, (20 16bit data) |
| | |
| DATA 0 | |
| CRC CHK Low | CRC check code: 16-bit CRC check code consists of two 8-bit combinations |
| CRC High | |
| CHK | |
| END | Keep no input signal greater than or equal to 10ms |

2.3 Local Protocol Parameter Address Definition

a) Function Code 03,06

| | | |
|---|-------|---------------------|
| Register data reading and writing (Function code 03, 06) | 0001H | Status register |
| | 0002H | Fault probe number |
| | 0003H | Alarm probe number |
| | 0004H | _____ |
| | 0005H | Mailing address R/W |
| | 0006H | Baud rate R/W |
| | 0007H | Version number |

b) Function Code 05

| | | |
|---|-------|-------------------|
| Coil bit data writing (Function code 05) | Bit1 | _____ |
| | Bit2 | _____ |
| | Bit3 | _____ |
| | Bit4 | _____ |
| | Bit9 | Alarm Elimination |
| | Bit10 | _____ |
| | Bit11 | Test spark |

Force single coil Bit9 ON status

Function: reset alarm command

Force single coil Bit11 ON state

Function: simulation test spark function command

V. TROUBLESHOOTING

During commissioning or use, the following table outlines some typical issues and troubleshooting techniques. You can contact the AMPE Service Department for technical support and servicing if the failure cannot be fixed in accordance with the following table.

| Faults | Causes | Parts to be checked | Troubleshooting |
|--|--|--|---|
| LED is not ON LCD display is OFF | <ol style="list-style-type: none"> 1. Power supply circuit problem 2. The plug at the rear of the panel is loose 3. The main control board is damaged | <ol style="list-style-type: none"> 1. If the AC220V power input voltage is typical 2. Inspect the cable plug holding the main board's operating panel in place to see if it is loose. 3. Inspect the main control panel's fuse. | <ol style="list-style-type: none"> 1. Reattach the cable 2. Reconnect the plug 3. Change the main board or the fuse. |
| Frequent alarm, several times daily, but no fire discovered | <ol style="list-style-type: none"> 1. The detection region is exposed to direct sunlight or reflection 2. Spark detection could be hurt. | <ol style="list-style-type: none"> 1. Verify the detection area's sealability and the presence of direct sunlight or reflections. 2. Check the Spark Detection in the control box to see which one generated the incorrect warning. | <ol style="list-style-type: none"> 1. Take steps to block light to prevent direct sunlight or reflections from reaching the detecting area. 2. Replace the Spark Detector that is broken. |
| When an alarm goes off, there is drive output voltage, but the fire exhaust mechanism is inactive. | Inspect the three-way flap mechanism's and the fire discharge mechanism's pneumatic components. | <ol style="list-style-type: none"> 1. Verify the compressed air pressure to make sure it is normal. 2. Is the solenoid valve and cylinder functioning normally? 3. If the three-way flap mechanism gets jammed. | <ol style="list-style-type: none"> 1. The pressure of compressed air returns to normal 2. Swap out pneumatic parts 3. Organize and correct the three-way fire exhaust system. |
| No response during spark test | <ol style="list-style-type: none"> 1. Spark detection is not installed 2. Spark Detection fault | <ol style="list-style-type: none"> 1. Check the connecting cable from Spark Detection to the motherboard 2. Check Spark Detection | <ol style="list-style-type: none"> 1. Install Spark Detection 2. Replace Spark Detection |

AMPE Technology Co., Ltd.

Tel: 86-519-8261230082616999 Fax: 86-519-82616555

www.ampecn.com